

Switching

- **Circuit Switching**
- **Packet Switching**
- **Message Switching**

Switched Network

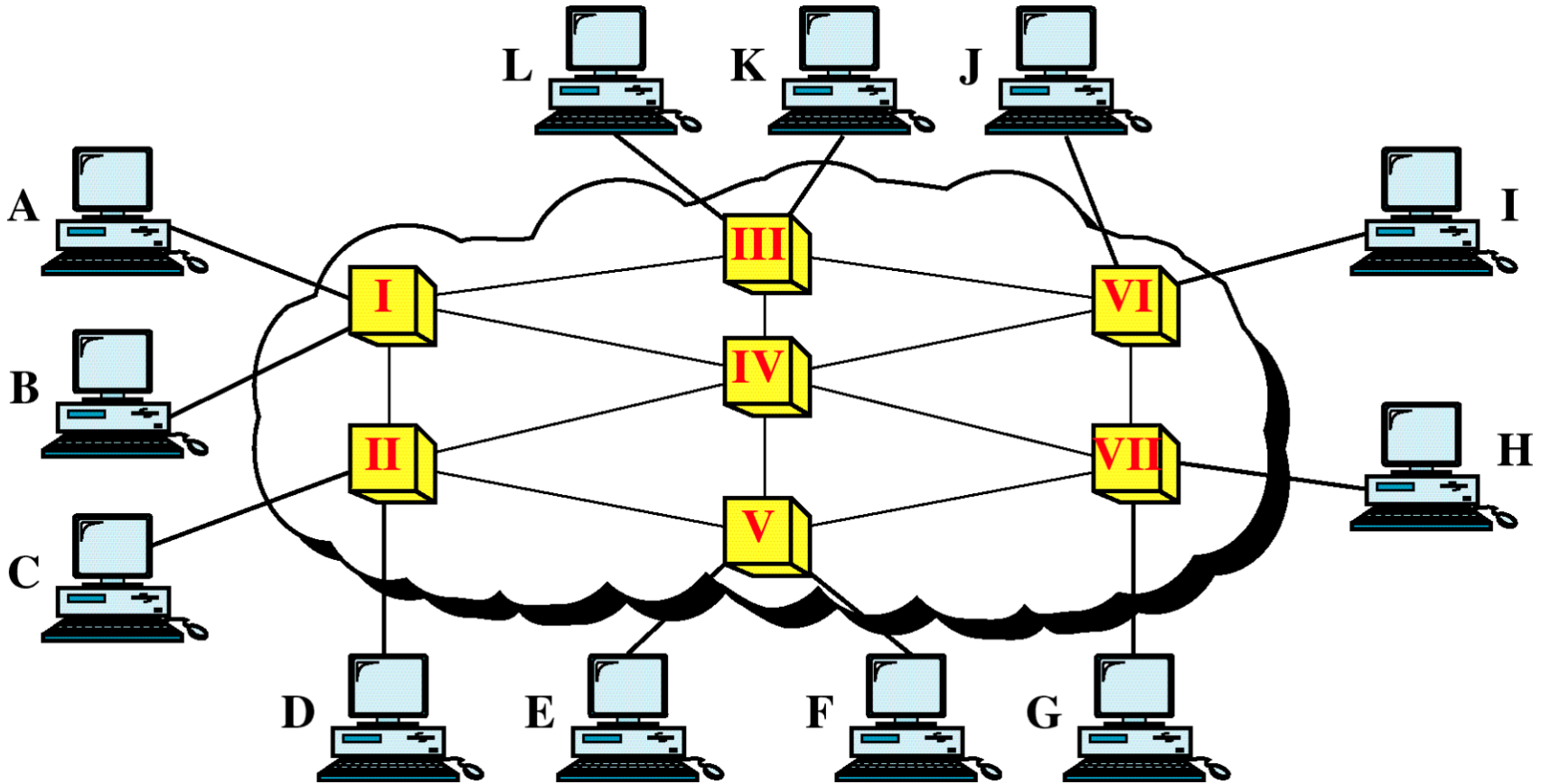

Switching methods

```
graph TD; A[Switching methods] --- B[Circuit switching]; A --- C[Packet switching]; A --- D[Message switching]
```

Circuit switching

Packet switching

Message switching

Circuit-Switched Network

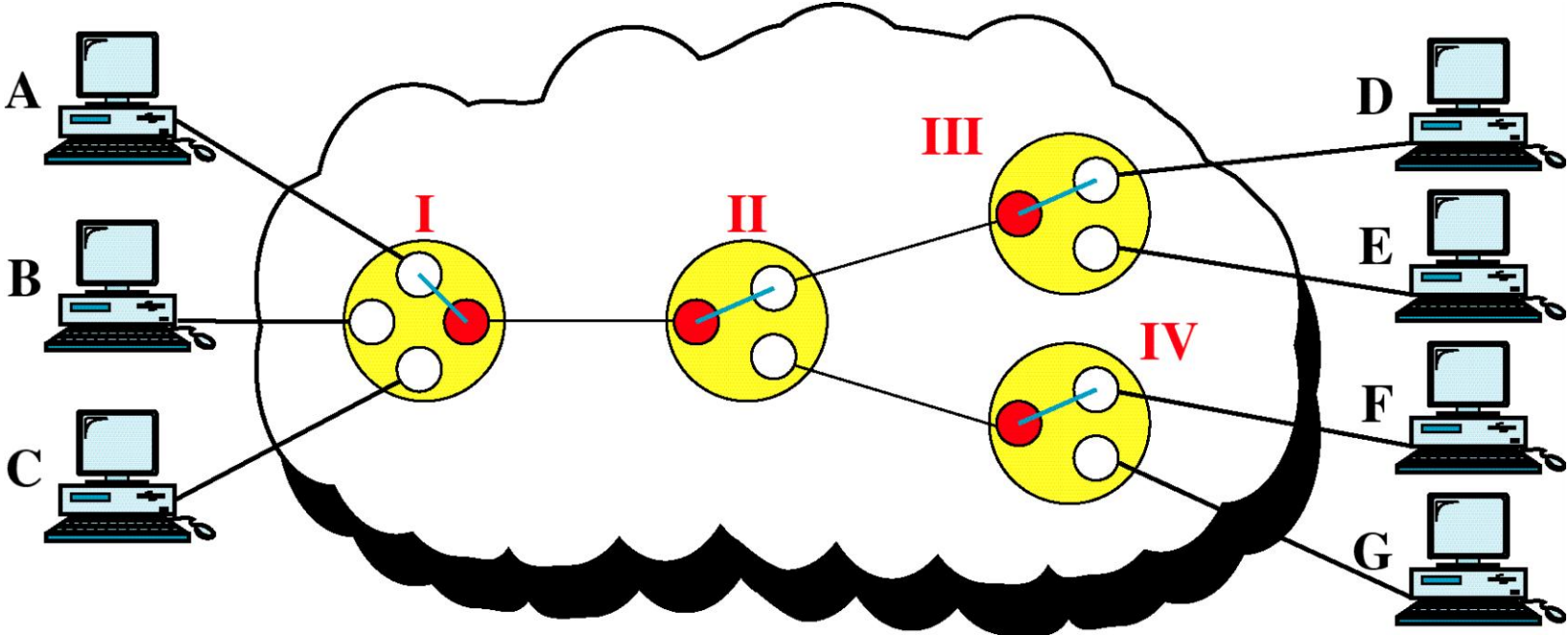

Switch

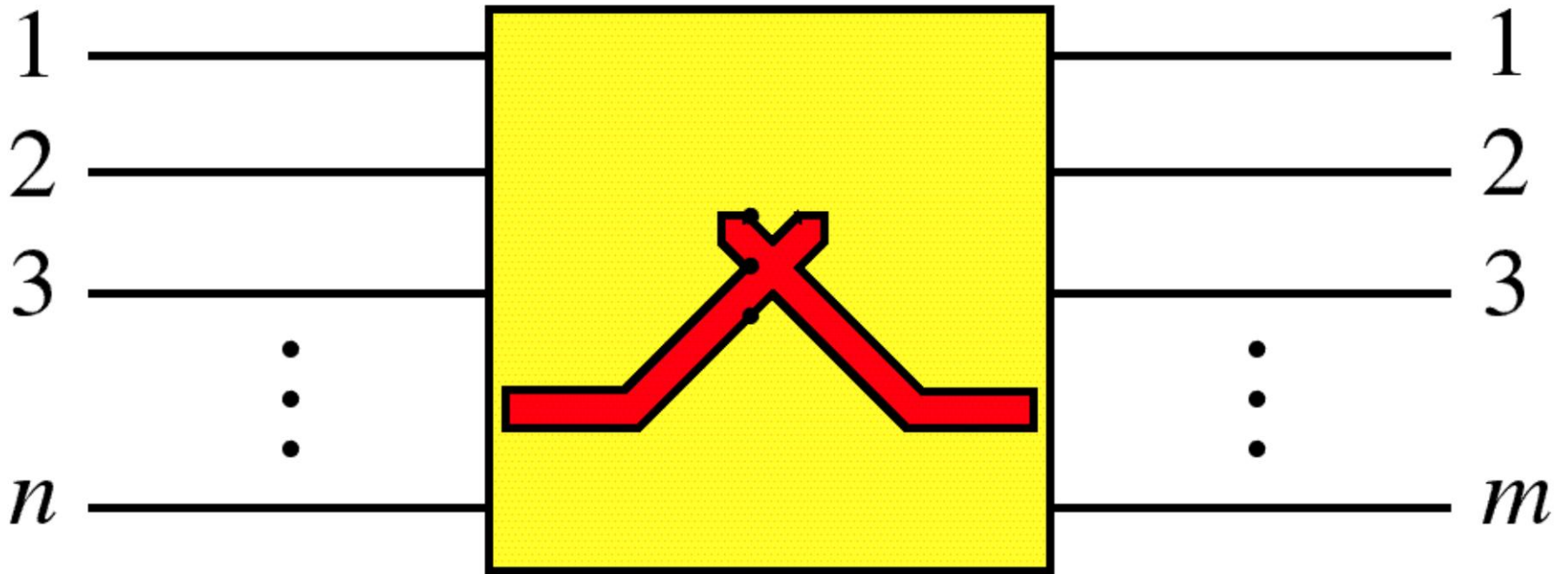

Folded Switch

Switch

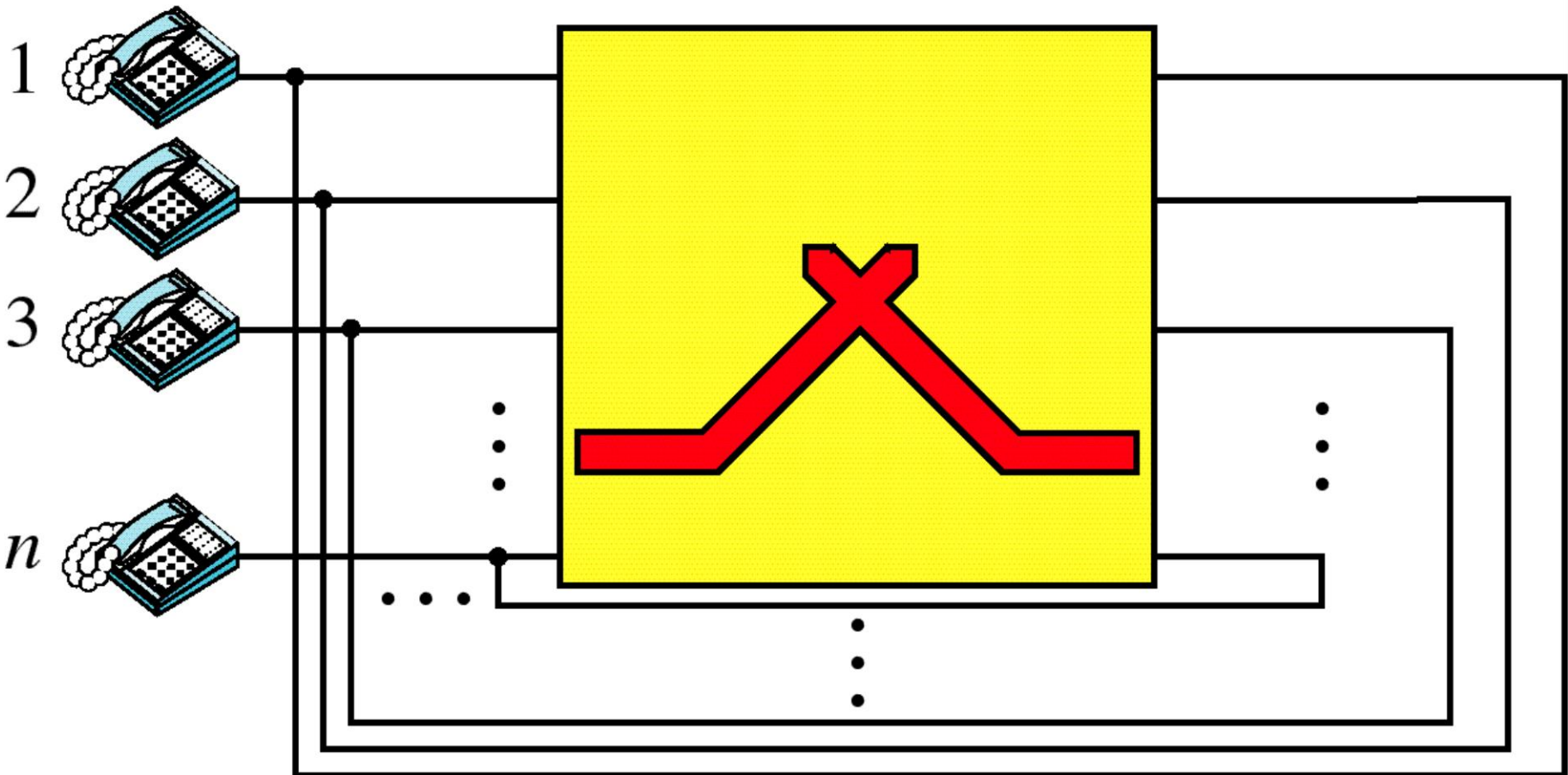

Circuit switching

```
graph TD; A[Circuit switching] --- B[Space-division switching]; A --- C[Time-division switching]
```

Space-division switching

Time-division switching

Crossbar Switch

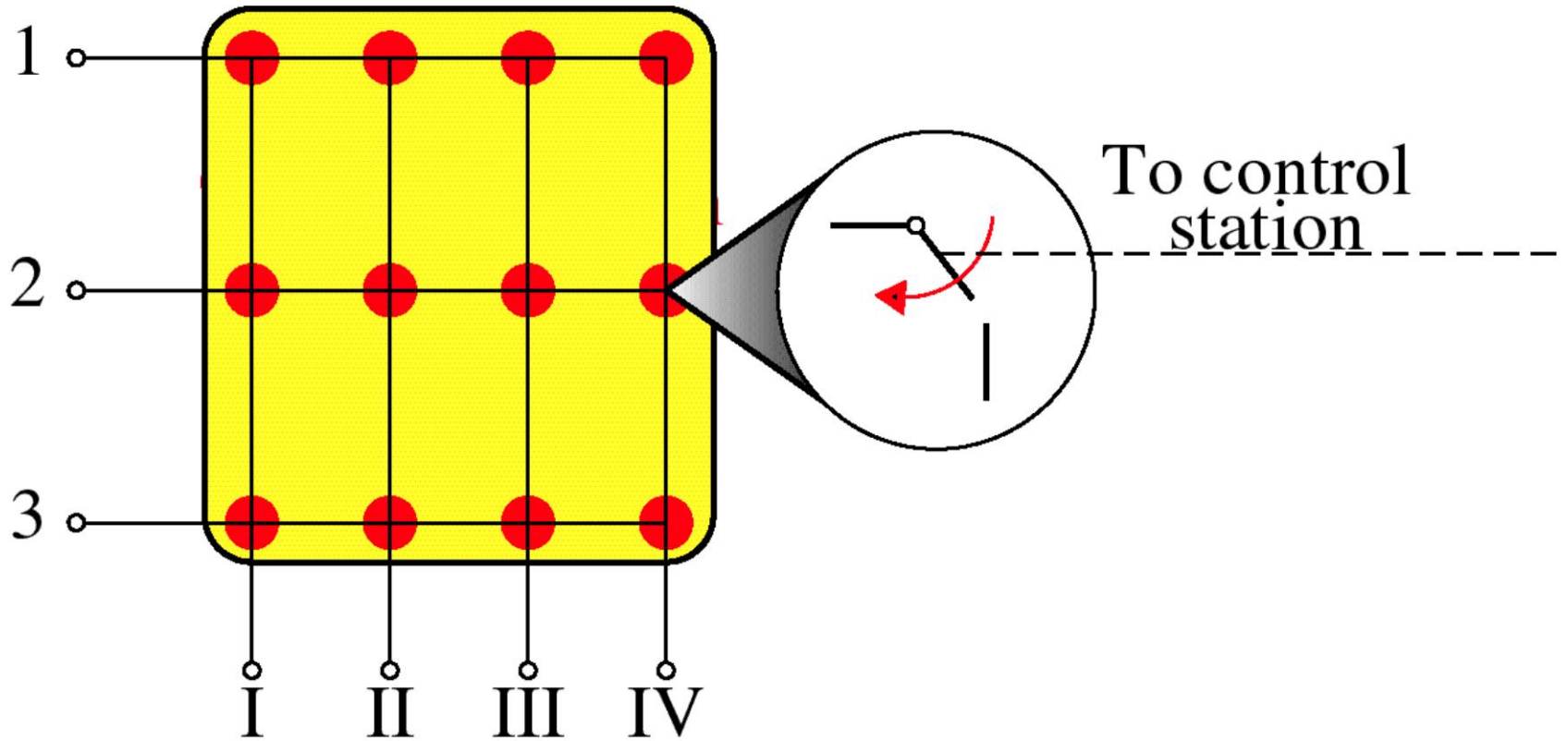

Multistage Switch

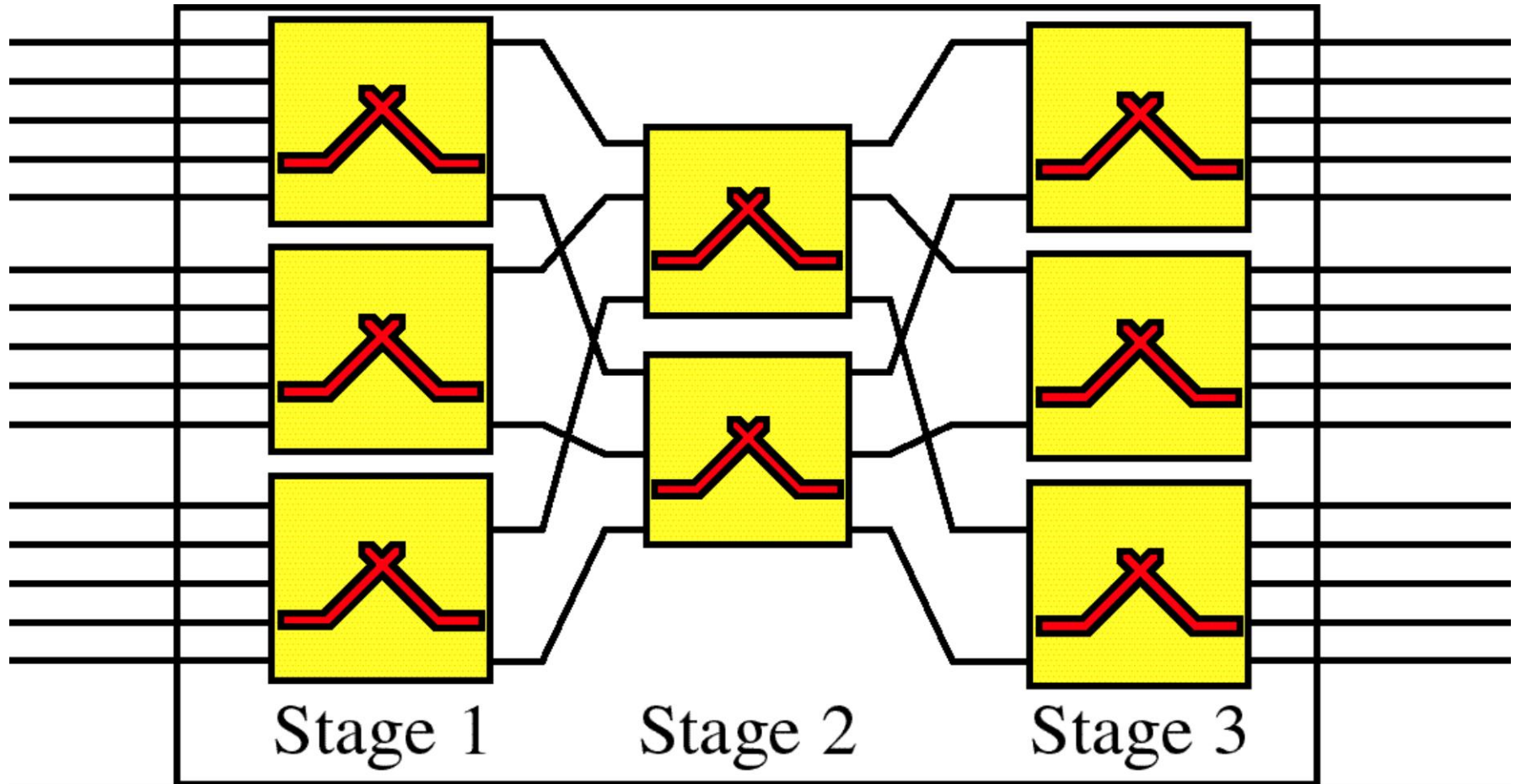

Switching Path

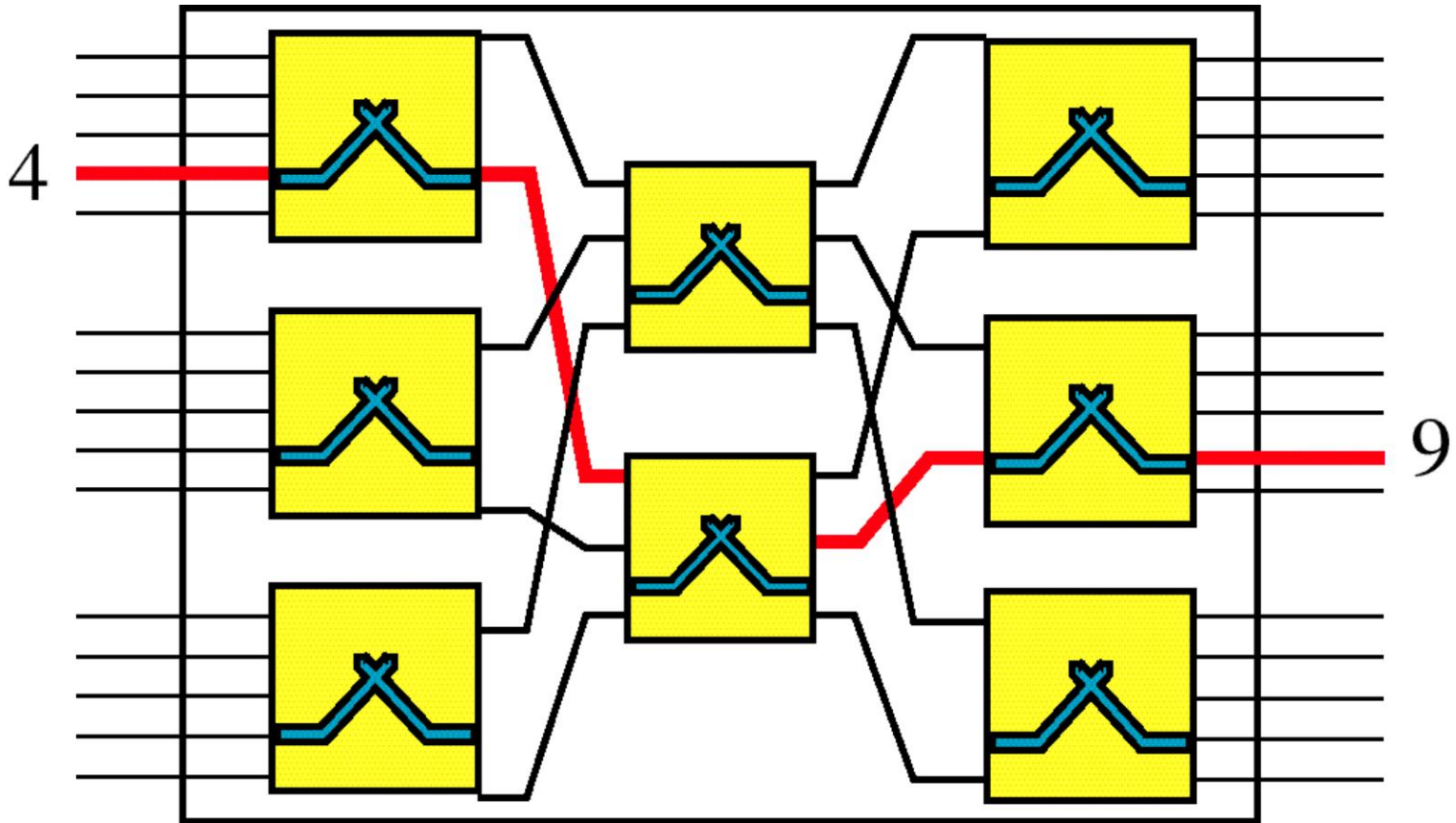

4 connected to 9

Switching Path

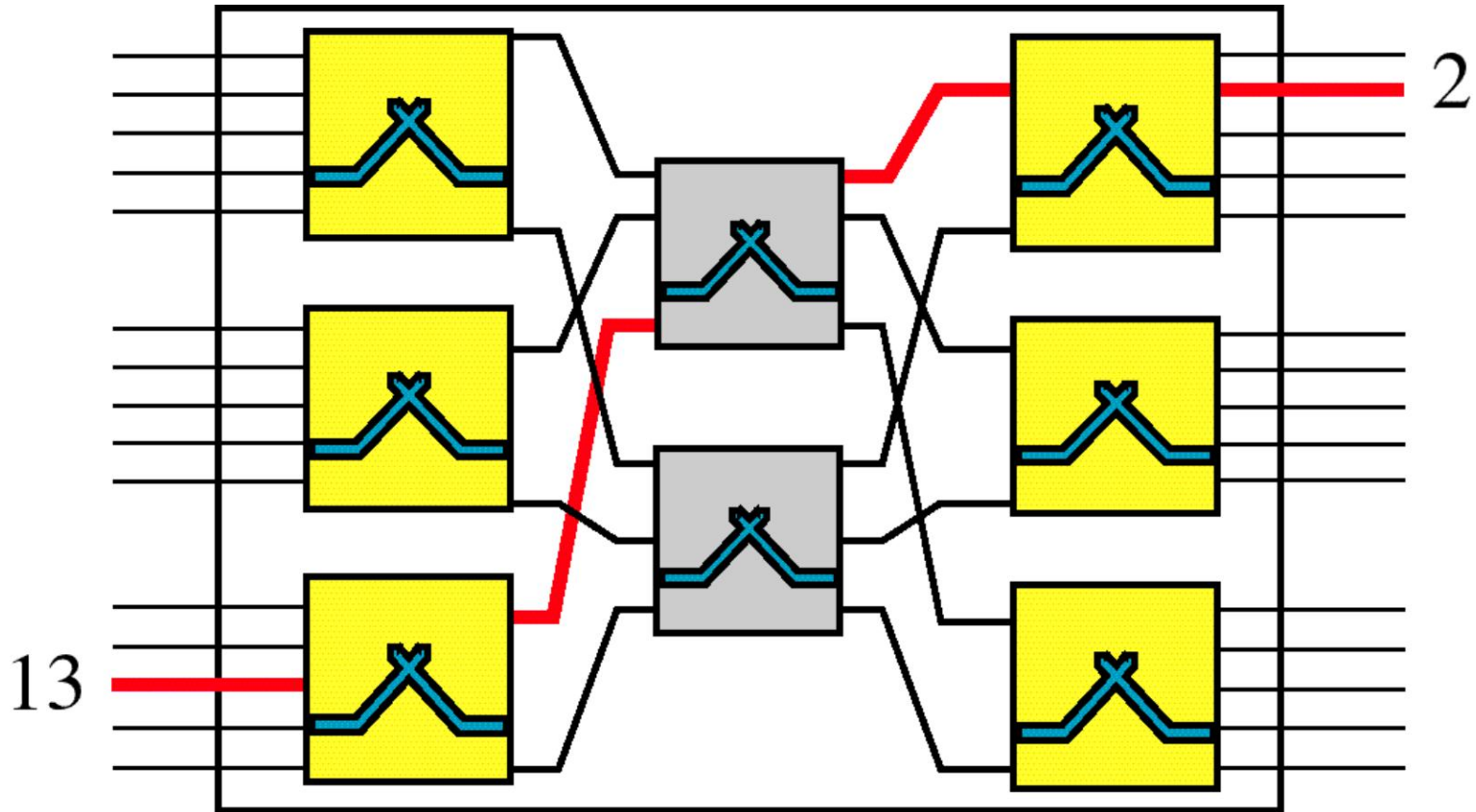

13 connected to 2

TDM without TSI

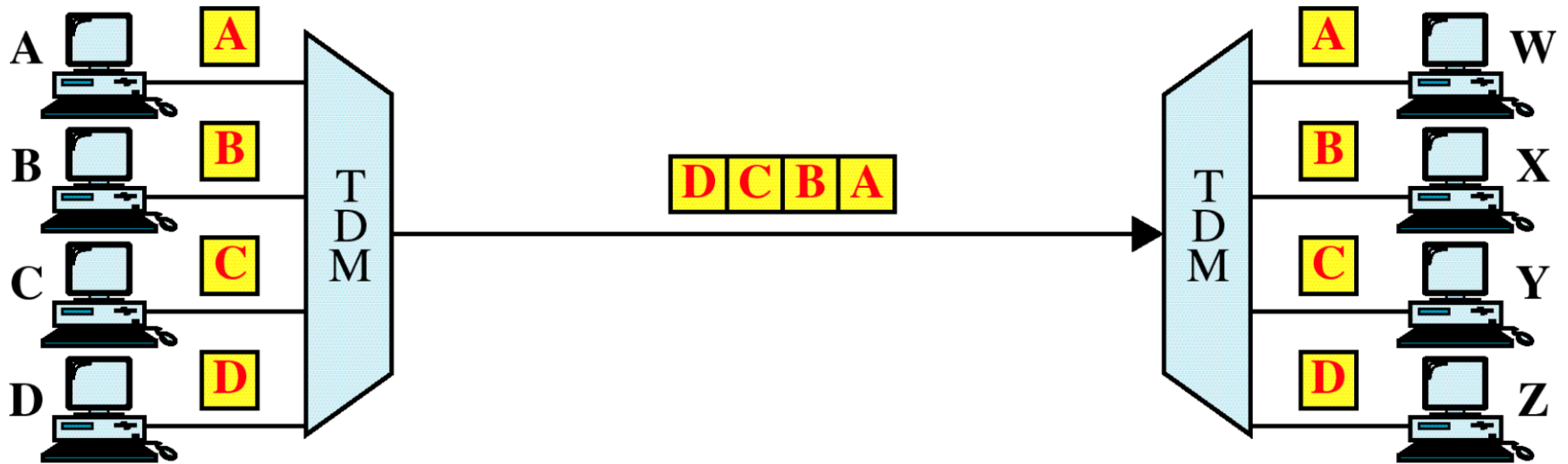

No switching

TDM with TSI

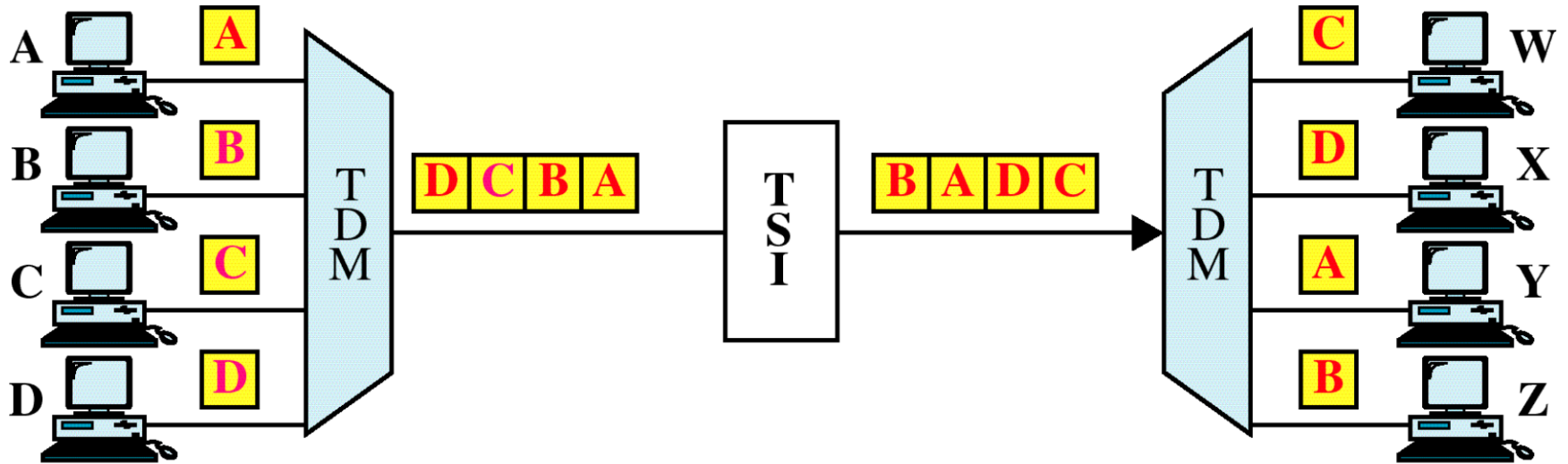

Switching

Time-Slot Interchange

TSI

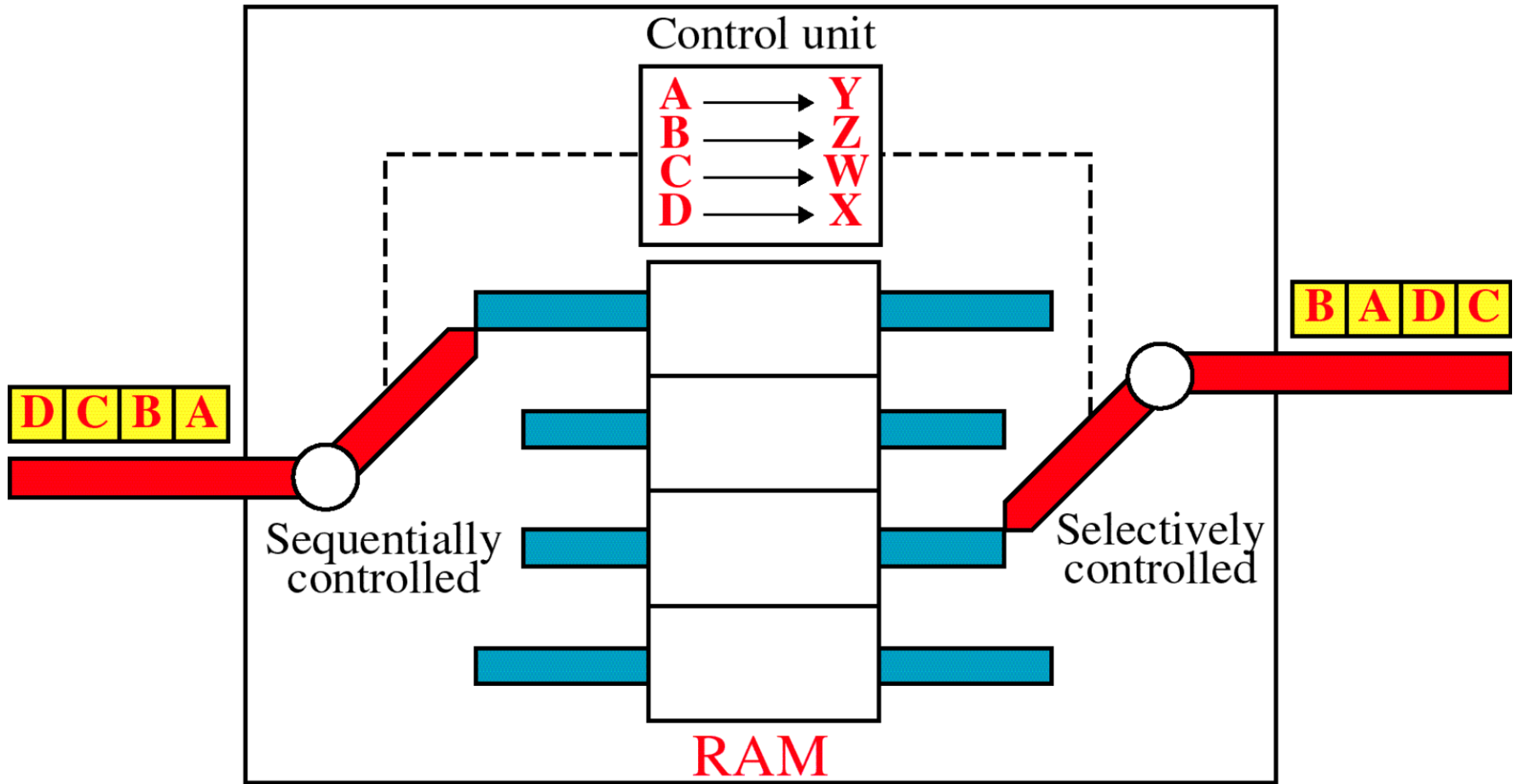

TST Switch

TST

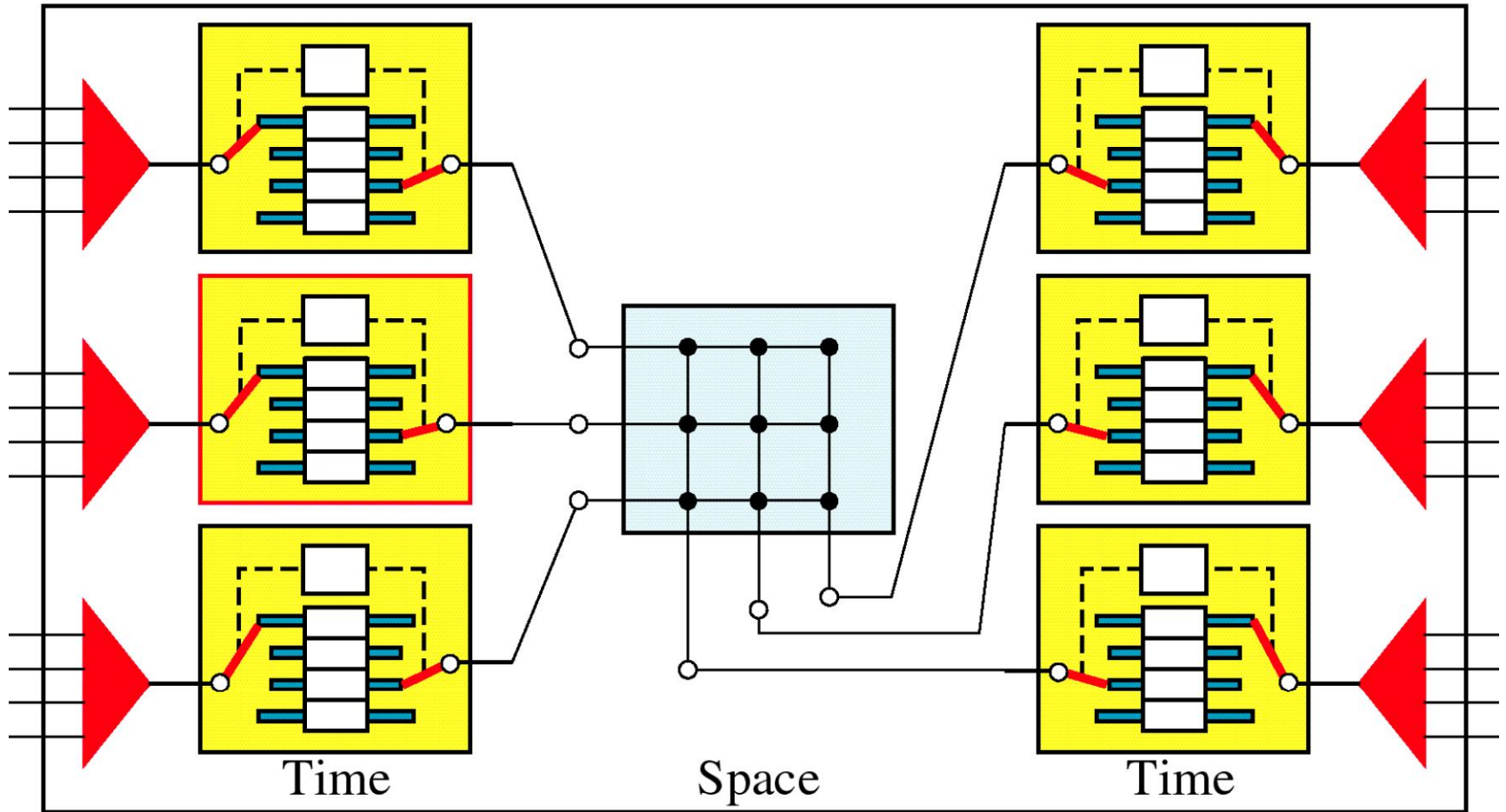

Packet switching

```
graph TD; A[Packet switching] --> B[Datagram approach]; A --> C[Virtual circuit approach];
```

Datagram approach

Virtual circuit approach

Datagram Approach

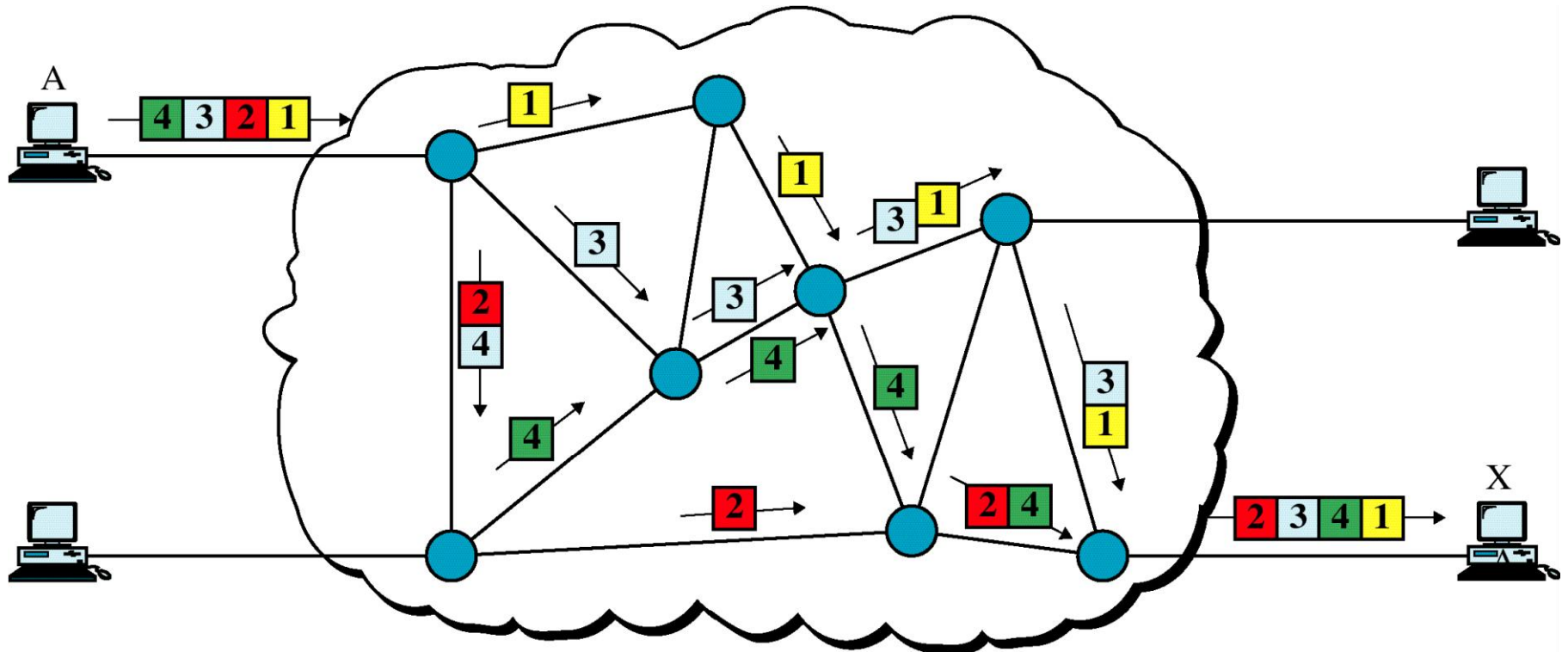

Datagram Approach, Multiple Channels

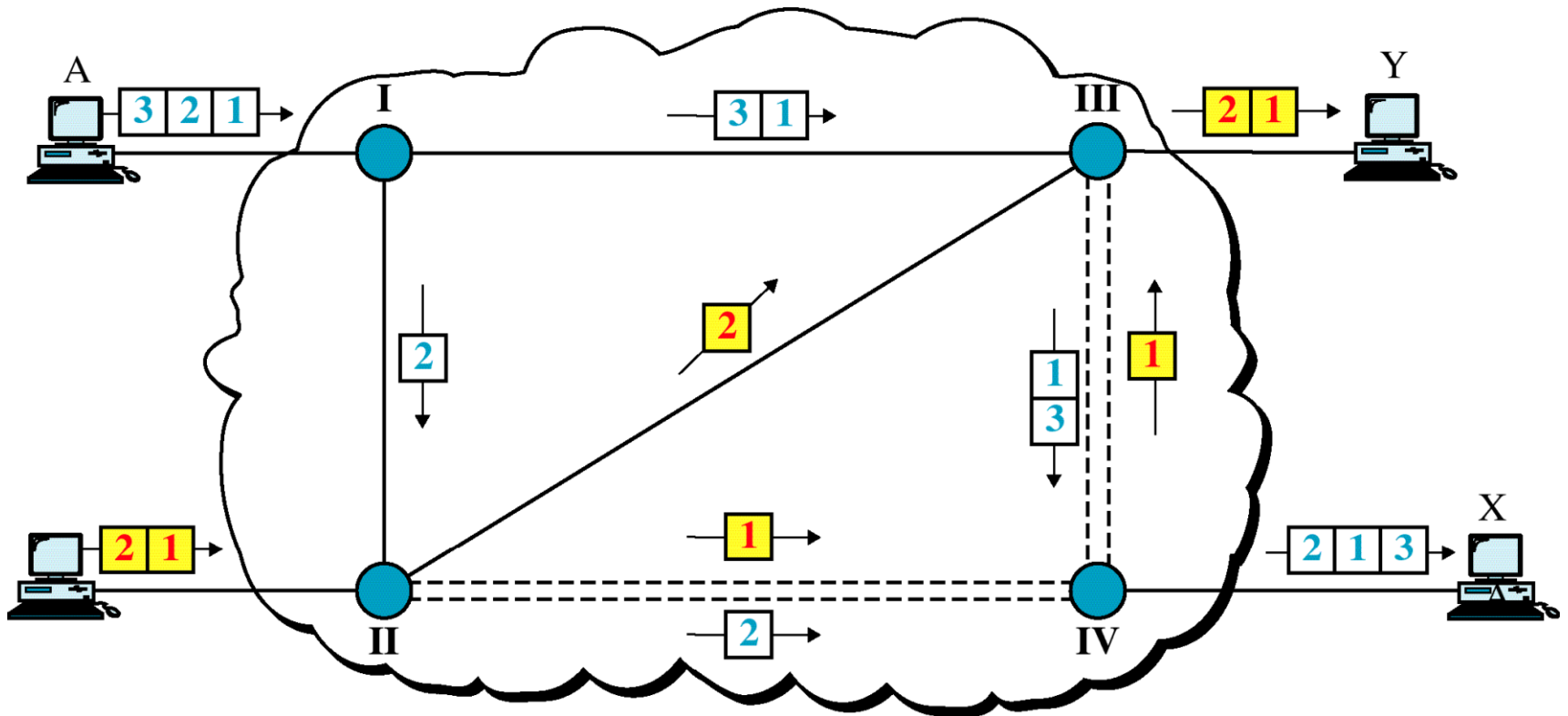

Switched Virtual Circuit

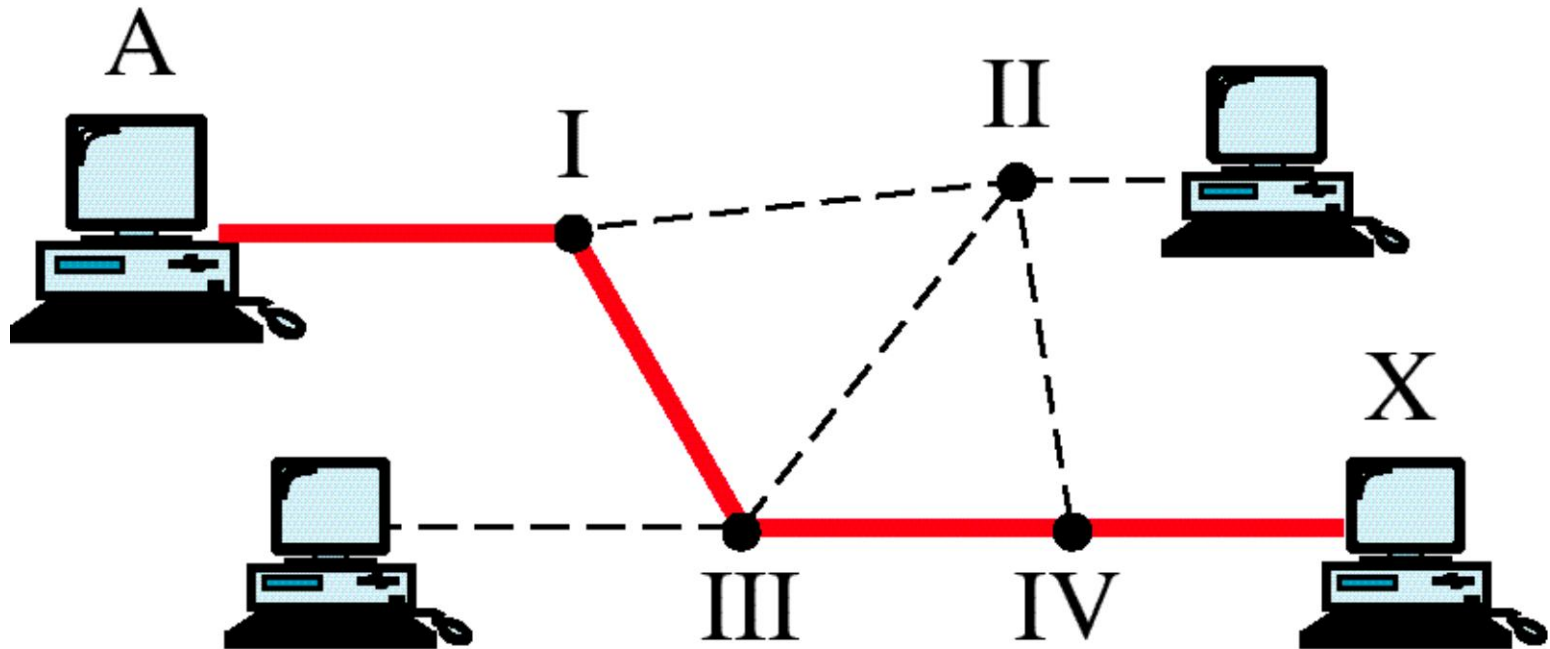

Connection establishment

Switched Virtual Circuit

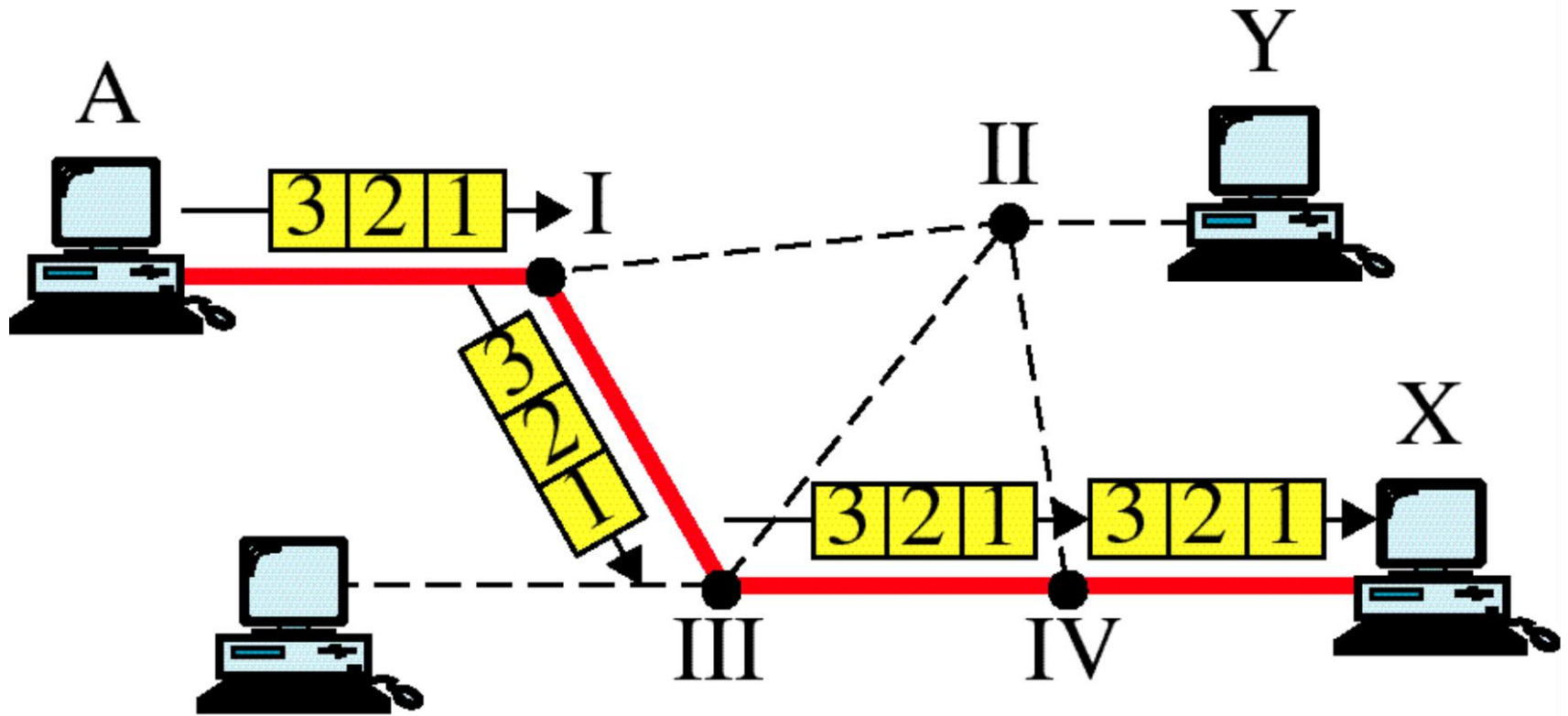

Data transfer

Switched Virtual Circuit

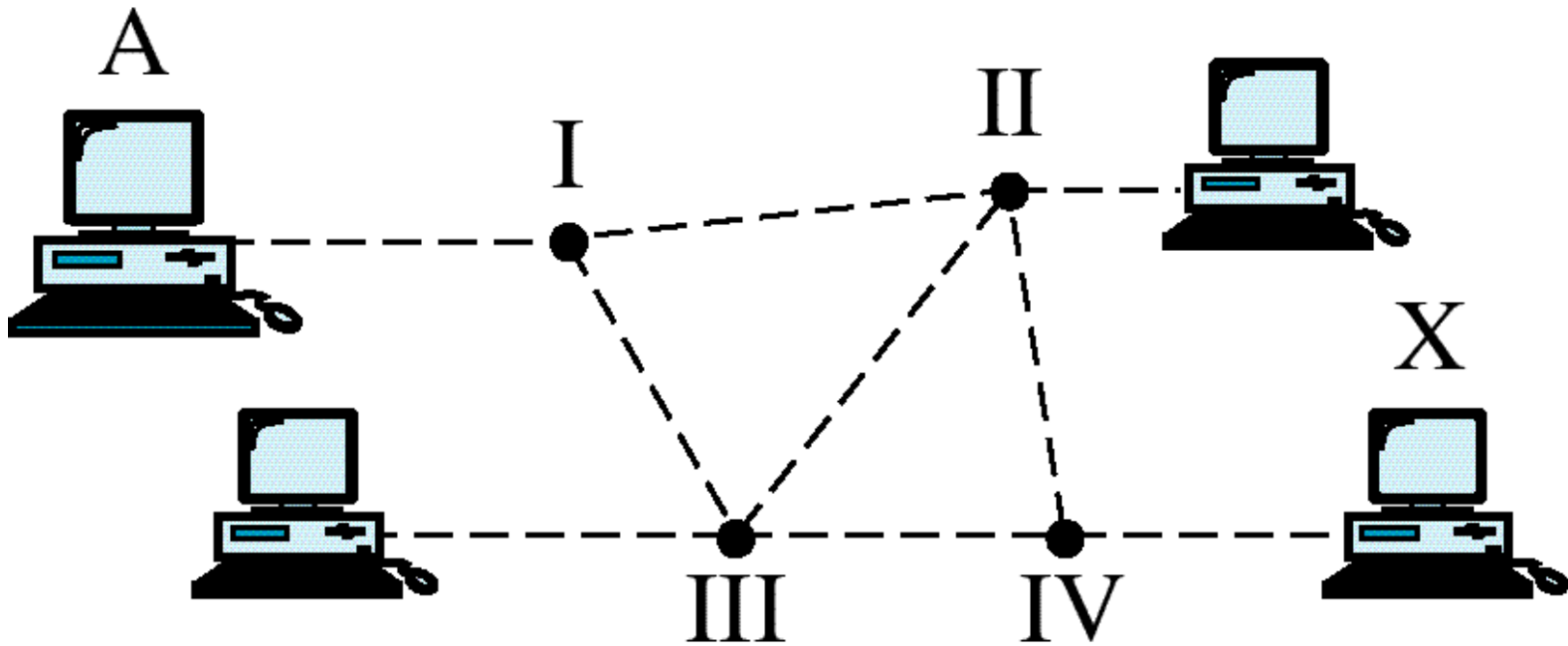

Connection release

Message Switching

